

16000 Mix

The 16000 Mix is a 16 scale weigher, used for weighing or counting three colored peppers to be packed together. The 16 buckets are divided in parts by five, five, and six buckets, with each part containing a different color pepper. The 16000 Mix can weigh or count the three color pack at rates up to 55 packages per minute. This makes the 16000 Mix a great addition to any bell pepper facility.

FEATURES

- 16 buckets to weigh bell peppers
- High speed computer scans the weights or counts in all 16 buckets and chooses the best combination to provide the best accuracy and speed
- Strong, stable frame with vibration isolation
- Touchscreen computer
- Optional router for remote assistance
- All product contact points are either stainless steel or plastic
- Weigher can count by piece or by weight
- Spedal elevator conveyor with three lanes
- Weigher divided into three parts, two lanes with five buckets, and one lane with six buckets
- Double discharge belts used for transport of products to the Flow Packer

DISCHARGE OPTIONS

Mix Discharge (for three color mix of bell peppers into horizontal Flow Packer)

PARTNER OPTIONS

Flow Packer



PACKAGE SIZE RANGE

1 to 5 pounds

CAPACITY / RATE

Up to 55 packages per minute*

AIR CONSUMPTION

6 CFM**

POWER

230 Volt, 3 Phase and Ground

MOST COMMON PRODUCTS

Bell Peppers

Custom testing available for any product.

* Depends on product, infeed, and discharge system.

** Actual air consumption will increase based on discharge system(s) chosen.

16000 Mix

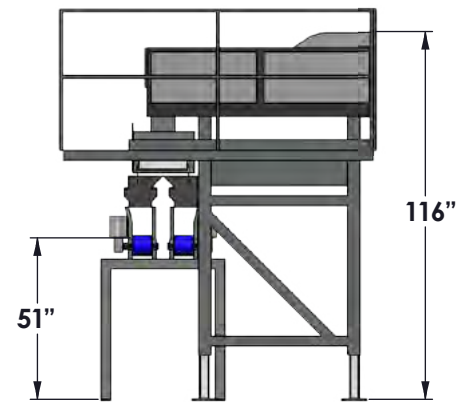
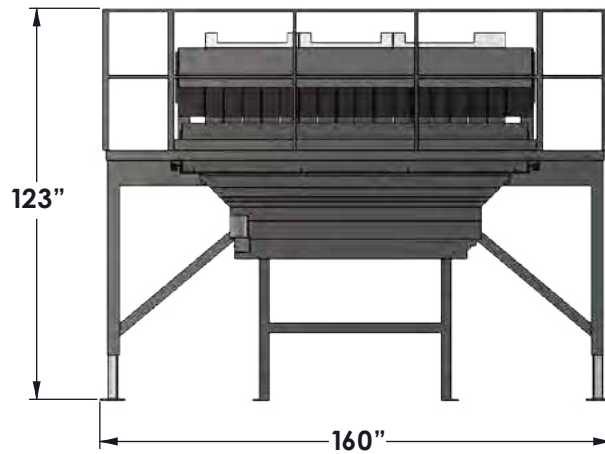
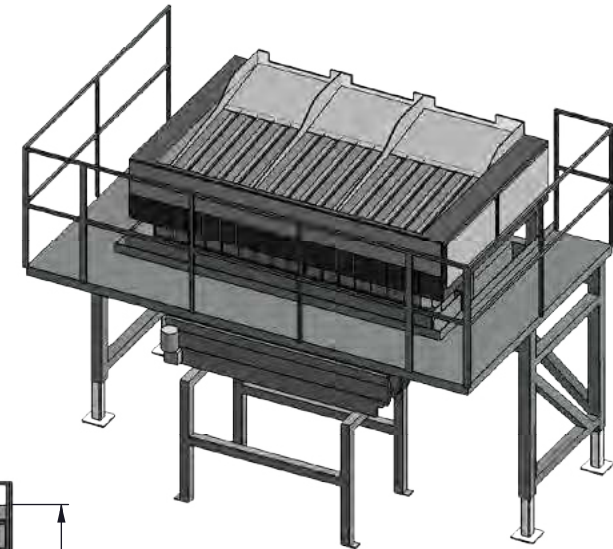
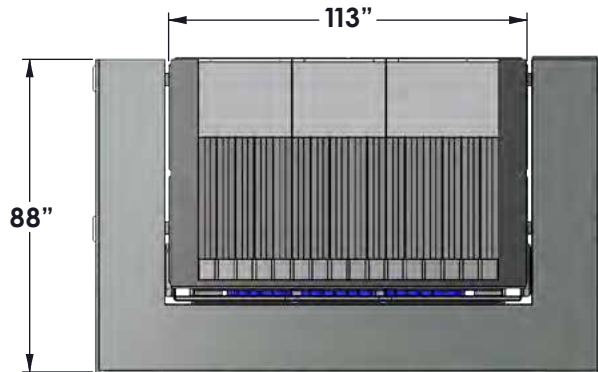

Measurements are rounded off to the nearest inch.