

## MD14 XL

The MD14 XL is equipped with 14 extra-large weighing buckets for high output. It is the largest, fastest, large bucket weigher in the Volmpack lineup. The MD14 XL also offers a packing range from 10 to 50 pounds at rates up to 40 bags per minute, which gives packing facilities a boost in production for large pack types.



### FEATURES

- Two rows of seven extra-large bucket scales to weigh a variety of large produce types
- High speed computer scans the weights available in all 14 buckets and chooses the best combination to provide the most accurate weight
- Strong, stable frame with vibration isolation
- Touchscreen computer
- Two computers for performing diagnostics or maintenance while also operating the weigher
- Operators can save packing styles in a user-friendly program for quick and easy changeovers
- Optional belts available versus vibrating lanes
- Optional router for remote assistance
- All product contact points are either stainless steel or plastic
- Large hopper for good spread of product over lanes

### DISCHARGE OPTIONS

- Single Discharge Belt
- Dual Discharge Belt
- Combination Bucket

### PARTNER OPTIONS

- Dual Wicket Bagger
- Carousel
- SemiPack
- AutoPack / AutoPack HS
- Rollstock Poly Bagger
- AutoMesh
- AutoMesh Plus
- Carton Filler

### PACKAGE SIZE RANGE

10 to 50 pounds

### CAPACITY / RATE

- 10 pounds up to 40 packages per minutes\*
- 20 pounds up to 30 packages per minutes\*
- 50 pounds up to 24 packages per minutes\*

### AIR CONSUMPTION

6 CFM\*\*

### POWER

230 Volt, 3 Phase and Ground

### MOST COMMON PRODUCTS

- Potatoes
- Onions
- Citrus Fruits
- Brussels Sprouts

Custom testing available for any product.

\* Depends on product, infeed, and discharge system.

\*\* Actual air consumption will increase based on discharge system(s) chosen.

# MD14 XL

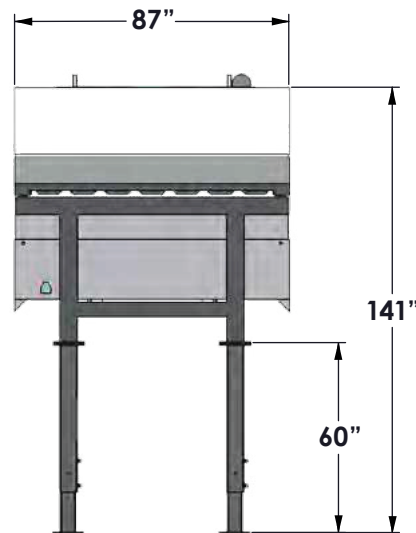
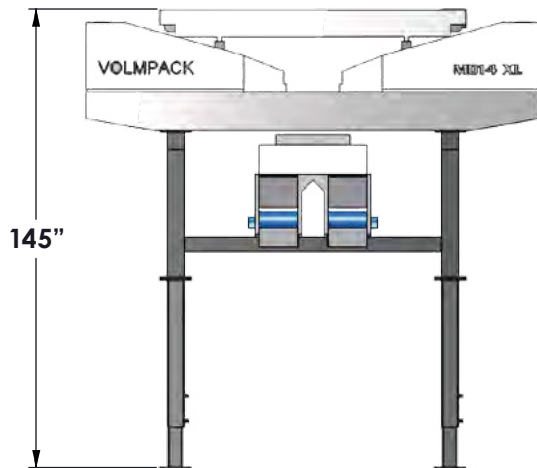
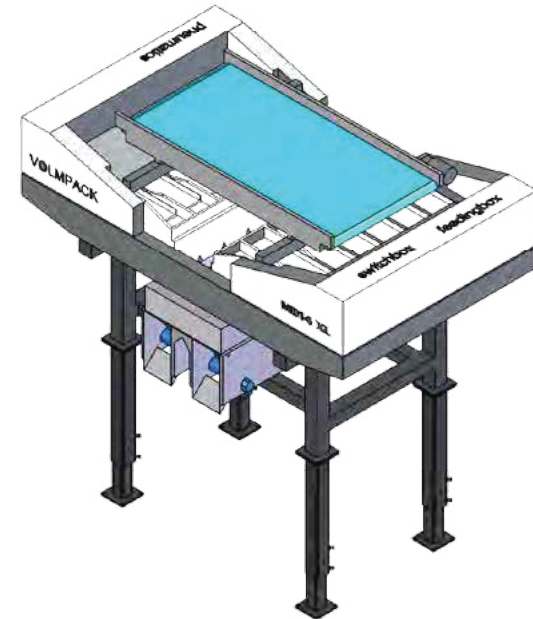
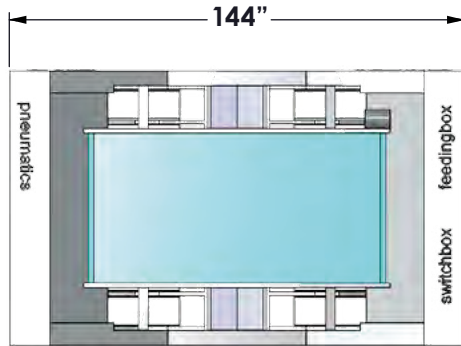

Measurements are rounded off to the nearest inch.