

VST 5 PALLETIZER

This palletizer is designed to use a minimal amount of floor space while maximizing saving on labor costs. Its sturdy design and minimal moving parts result in a very low maintenance interval.

It can reach a capacity of 10 bags per minute. The manipulator positions your product with the utmost accuracy to offer high stacking quality. The user-friendly controls are very intuitive. The programmable controls offer a setup that will meet all of your requirements.

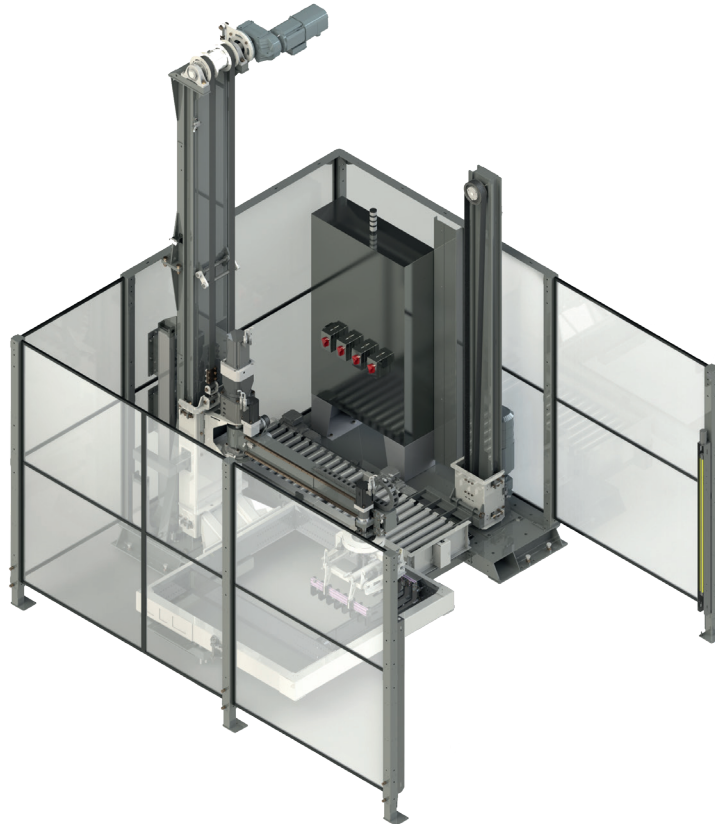

FEATURES

- Capacity of up to 10 bags per minute
- Multi-programmable stacking patterns are available
- Adjustable collar capable of palletizing up to a 50" x 50" pallet
- Touchscreen for easy operation
- Standard LAN connectivity for remote access
- Integrated pallet guide with adjustable stops allows for palletizing with up to a 3" overhang on pallet.

BAG SPECIFICATIONS

MANIPULATOR	
MINIMUM WEIGHT	40lbs / 18kg
MAXIMUM WEIGHT	60lbs / 27kg
WIDTH	15in / 381mm
LENGTH	26in / 660mm

SPECIFICATIONS

- Pallet Sizes: Any pallet up to 4'2" (1270 mm)
- Maximum stacking height of 8'2" (2500mm) including pallet
- Air Consumption varies based on options chosen
- Power:
480 Volt, 3 Phase, Ground, 60 Hz

VST 5 PALLETIZER

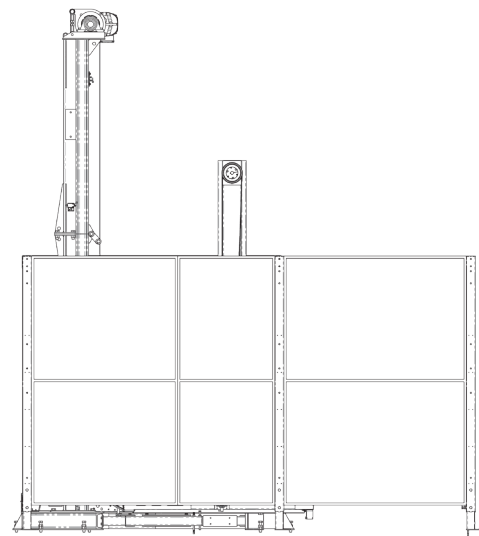
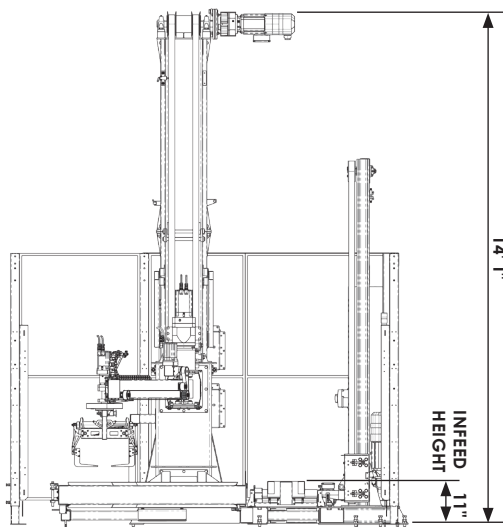
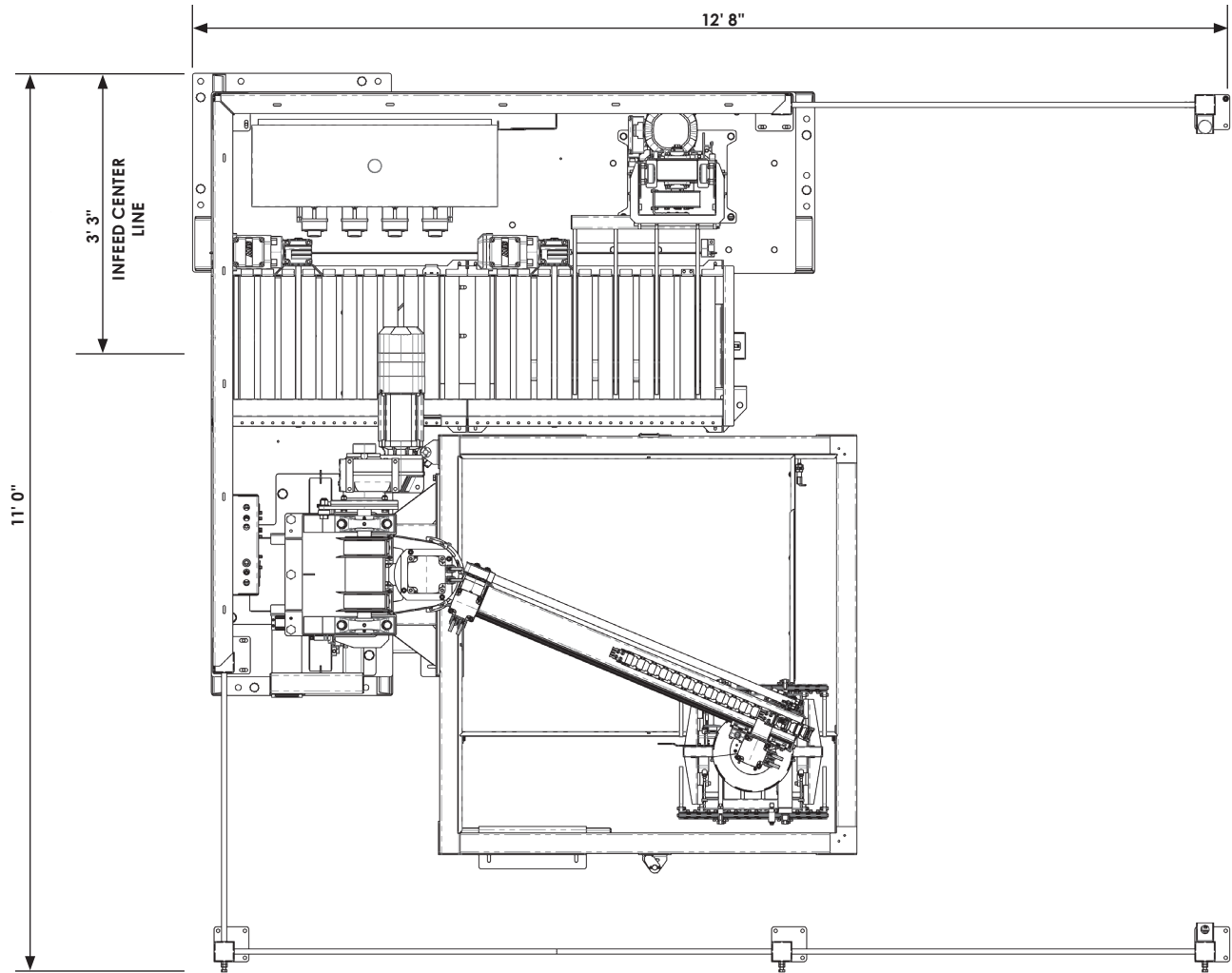

Measurements are rounded to the nearest inch