

M10i D

The Volmpack M10i D is one of our smaller, high-capacity, stainless steel weighers. With its small footprint, vibrating lanes and easy-to-remove dosing & weighing buckets for quick cleaning and maintenance, this weigher would be great for any retail packing line.

The M10i D offers a packing range from 1 to 10 pounds at rates up to 50 bags per minute, which is excellent for many consumer pack styles.



FEATURES

- 10 bucket scales to weigh a variety of produce types
- The touchscreen computer scans the weights of all the buckets and chooses the best combination to provide the most accurate weight
- The 10 dosing and weigher buckets are designed for quick removal for minimal downtime for cleaning and maintenance
- Robust and stable frame with vibration isolation
- Operators can save packing styles in the user-friendly program for quick and easy changeovers
- Newly designed vibrating lanes for quick transportation of product to the buckets
- Built-in router for remote assistance
- All product contact points are either stainless steel or plastic

DISCHARGE OPTIONS

- Single Belt Discharge
- Dual Belt Discharge
- Center Discharge System

PARTNER OPTIONS

Wicket Baggers
Pouch Bagger
Rollstock Poly Bagger
Rollstock Pouch Bagger
VFFS Bagger

PACKAGE SIZE RANGE

1 to 10 pounds

CAPACITY / RATE

- 1 pound up to 50 packages per minute*
- 10 pounds up to 40 packages per minute*

AIR CONSUMPTION

5 CFM**

POWER

230 Volt, 3 Phase and Ground

MOST COMMON PRODUCTS

- Potatoes
- Onions
- Carrots
- Citrus
- Garlic

Custom testing available for any product.

* Depends on product, infeed and discharge system.

** Actual air consumption will increase based on discharge system(s) chosen.

M10i D

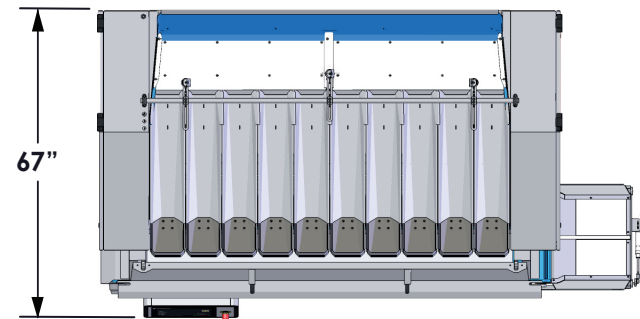
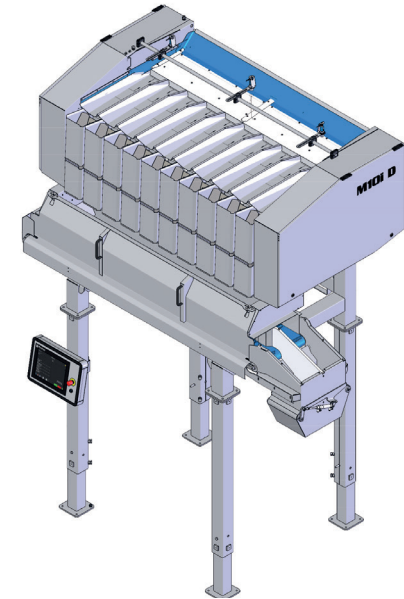
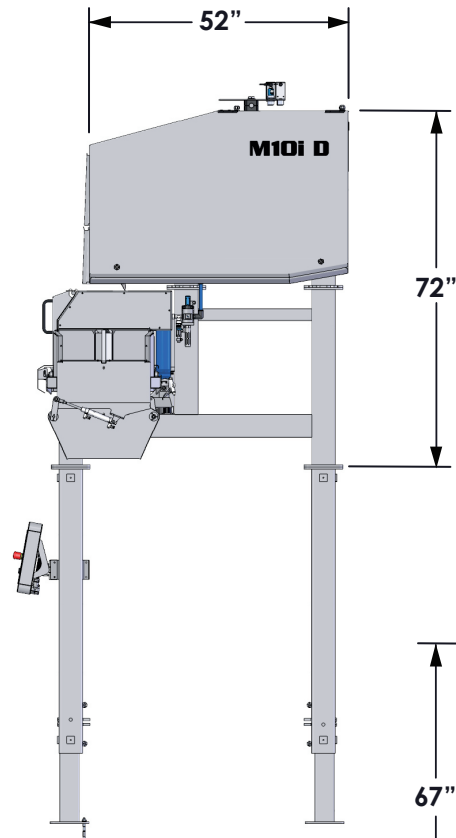
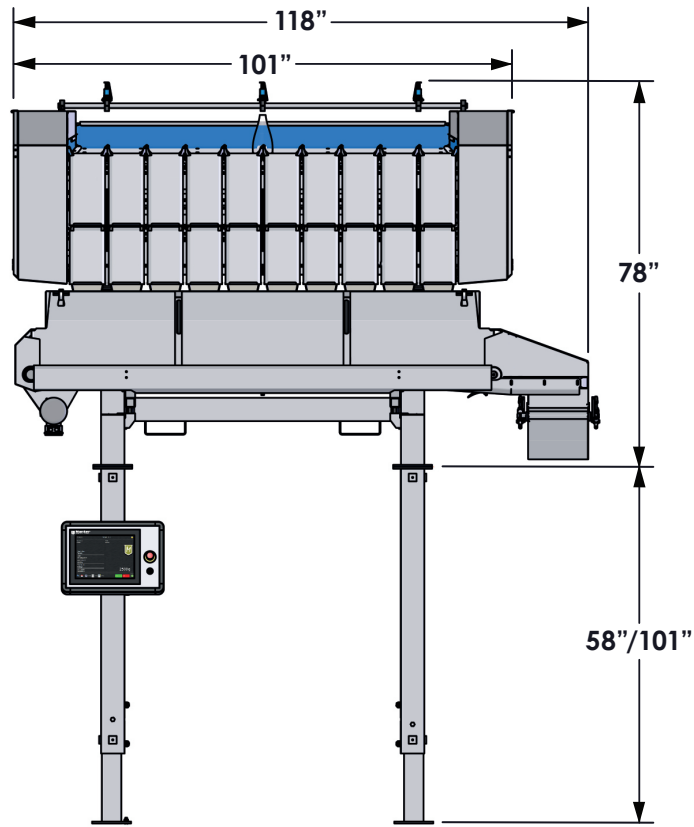

Measurements are rounded off to the nearest inch.