

## MD10 XL

The MD 10XL is the little brother of the MD 14XL. The MD10 XL is equipped with 10 extra-large weighing buckets for high output. The MD10 XL also offers a packing range from 10 to 50 pounds at rates up to 30 bags per minute, which gives packing facilities a boost in production for large pack types.



### FEATURES

- Two rows of five extra-large bucket scales to weigh a variety of large produce types
- High-speed computer scans the weights available in all 10 buckets and chooses the best combination to provide the most accurate weight
- Strong, stable frame with vibration isolation
- Touchscreen computer
- Operators can save packing styles in user-friendly programs for quick and easy changeovers
- Optional belt available versus standard vibrating lanes
- Standard router for remote assistance
- Large hopper for good spread of product over lanes
- All product contact points are either stainless steel or food grade plastic

### DISCHARGE OPTIONS

- Single Discharge Belt
- Dual Discharge Belt

### PARTNER OPTIONS

- SemiPack
- AutoPack / AutoPack HS
- Rollstock Poly Bagger
- AutoMesh
- AutoMesh Plus
- Carton Filler
- Wicket Baggers

### PACKAGE SIZE RANGE

10 to 50 pounds

### CAPACITY / RATE

10 pounds up to 30 bags per minute\*  
50 pounds up to 16 bags per minute\*

### AIR CONSUMPTION

5 CFM\*\*

### POWER

230 Volt, 3 Phase and Ground

### MOST COMMON PRODUCTS

- Potatoes
- Onions
- Citrus Fruits

Custom testing available for any product.

\* Depends on product, infeed, and discharge system.

\*\* Actual air consumption will increase based on discharge system(s) chosen.

# MD10 XL

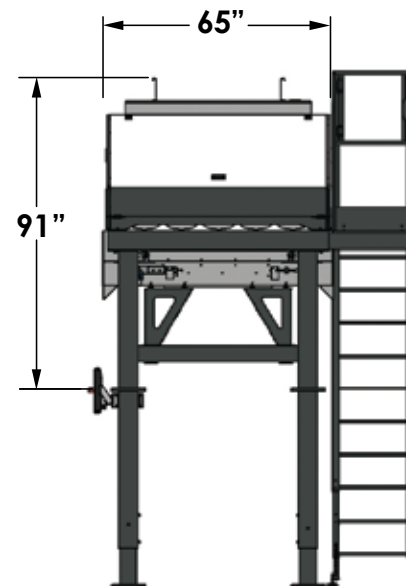
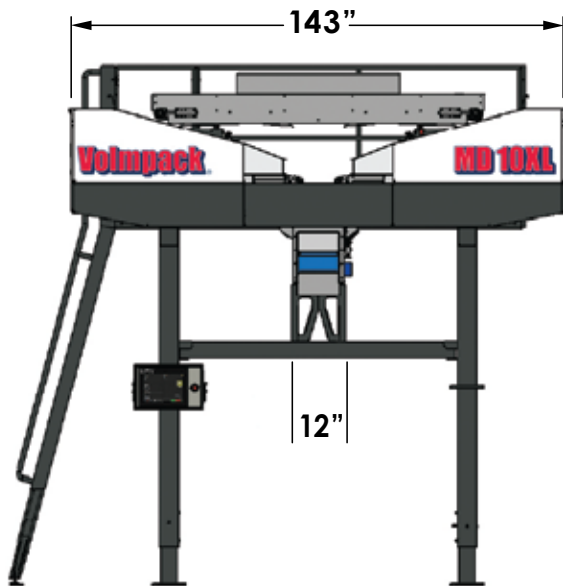
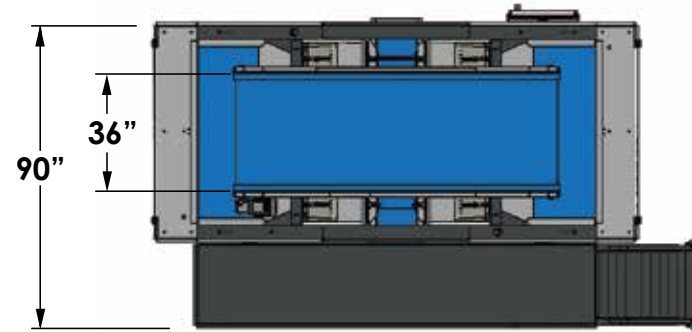

Measurements are rounded off to the nearest inch.